



晶采光電科技股份有限公司  
AMPIRE CO., LTD.

# Specifications for LCD module

Customer	
Customer part no.	
Ampire part no.	AM-1024768Z6TZQW-00H
Approved by	
Date	

- Preliminary Specification  
 Formal Specification

**AMPIRE CO., LTD.**

**4F., No.116, Sec. 1, Xintai 5th Rd., Xizhi Dist., New Taipei City 221, Taiwan (R.O.C.)**

**新北市汐止區新台五路一段 116 號 4 樓(東方科學園區 A 棟)**

**TEL:886-2-26967269 , FAX:886-2-26967196 or 26967270**

Approved by	Checked by	Organized by
Patrick	Kokai	Jessica

This Specification is subject to change without notice.

## RECORD OF REVISION

<b>Revision Date</b>	<b>Page</b>	<b>Contents</b>	<b>Editor</b>
2021/10/27	-	New Release	Jessica
2021/12/20	1,18,19	Change to official part-number	Jessica
	11	Add color chromaticity and NTSC value	Jessica
2022/01/18	5,7,11	Update VDD Power, Timing, Contrast & Response time	Lawlite
2022/7/8	20	Update drawing	Lawlite
2022/09/28	10	Remove 6.3 Touch Panel Controller Board Pin Assignment	Tank

## 1. Features

12.1 TFT Liquid Crystal Display module is a color active matrix thin film transistor (TFT) liquid crystal display (LCD) that uses amorphous silicon TFT as a switching device. It is composed of a TFT LCD panel, a driving circuit and a back light system. This TFT LCD has a 12.1 inch diagonally measured active display area with HD (1024 horizontal by 768 vertical pixels) resolution.

(1) Enhance display color performance by wide color gamut LED backlight.

## 2. Physical Specifications

Item	Specifications	Remark
LCD size	12.1 inch(Diagonal)	
Driver element	a-Si TFT active matrix	
Display resolution	1024 (W) × 3(RGB) ×768(H) dots	
Display mode	Normally Black	
Dot pitch	0.240 (W) ×0.240 (H) mm	
Color arrangement	RGB Vertical Stripe	

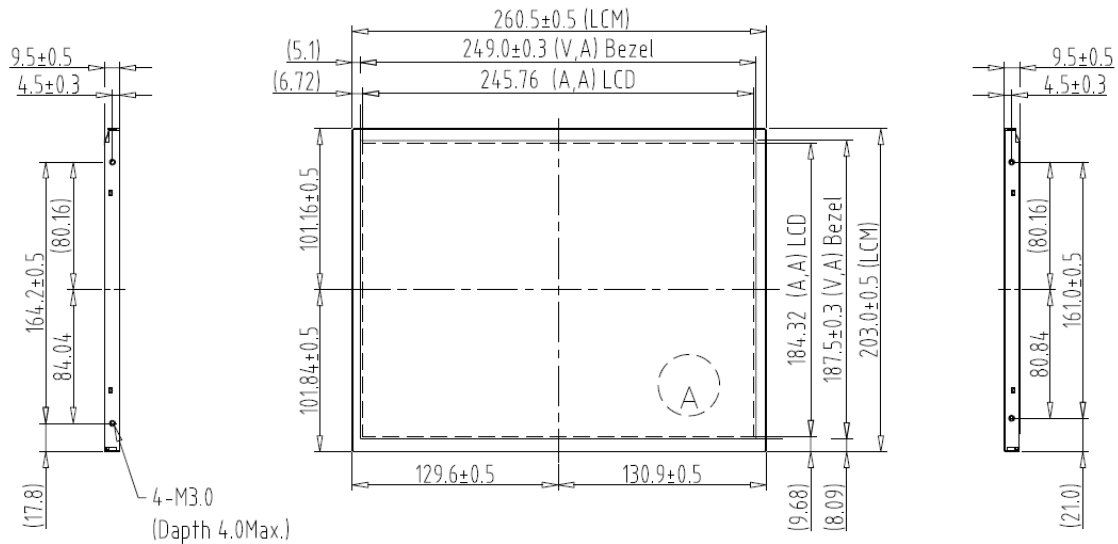

### 3. Absolute Maximum Ratings

Item	Symbol	Values		Unit	Remark
		Min	Max		
LCD Power Voltage	VDD	-0.3	5.0	V	
Operation Temperature	TOP	<b>-30</b>	<b>70</b>	°C	
Storage Temperature	TST	<b>-30</b>	<b>80</b>	°C	

Note(1) The absolute maximum rating values of this product are not allowed to be exceeded at any times.

Note(2) Should a module be used with any of the absolute maximum ratings exceeded, the characteristics of the module may not be recovered, or in an extreme case, the module may be permanently destroyed.

## 4. Electrical Specifications

### 4.1 TFT LCD module

Item	Symbol	Min.	Typ.	Max.	Unit	Note
Supply Voltage	VDD	3.0	3.3	3.6	V	
Logic Input Voltage	VIH	0.8xVDD	--	VDD	V	BIST,SEL68,reLR,reUD
	VIL	0	--	0.2xVDD	V	
Current of power supply	IDD	—	0.25	—	A	VDD =3.3V · white pattern (L255)
VDD Power	PDD	—	--	6.6	W	VDD =3.3V · white pattern (L255)
Inrush current	IRUSH	—	—	2.0	A	Note*

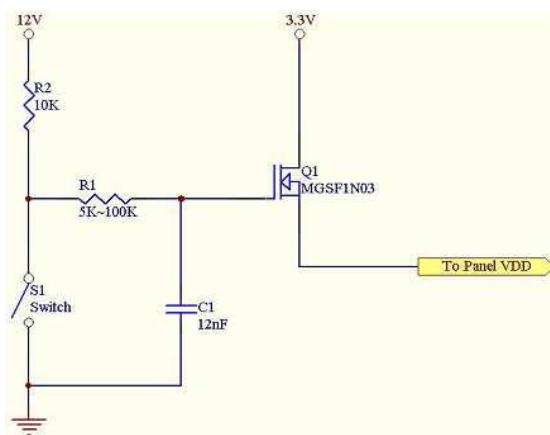

Test circuit

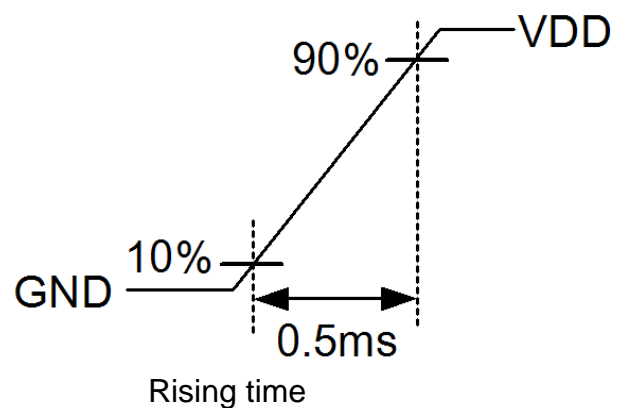

### 4.2 Switching Characteristics for LVDS Receiver

Item	Symbol	Min.	Typ.	Max.	Unit	Conditions
Differential Input High Threshold	VTH	100		300	mV	
Differential Input Low Threshold	VTL	-300			mV	
Differential input common mode voltage	VCM	1.0	1.2	$1.7 - \frac{ VID }{2}$	V	
Input Current	IIN	-10		10	uA	RX+/-, RXC+/-
Differential input Voltage	VID	200		600	mV	

### 4.3 Bit LVDS input

#### 4.3.1 6bit LVDS input

Pin4 SEL68=0: LVDS input data is 6bits (VESA)

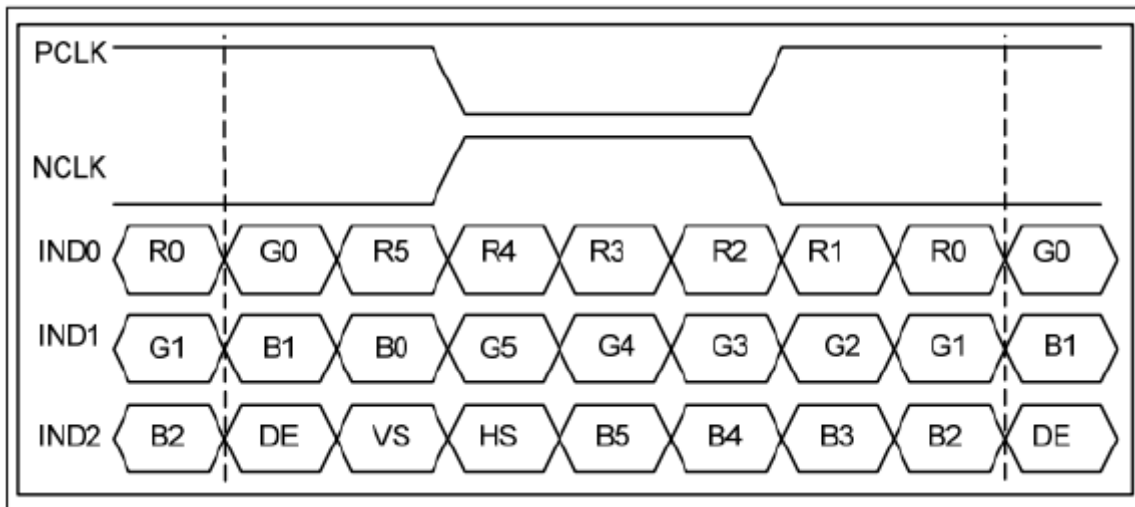

#### 4.3.2 8Bit LVDS input

Pin4 SEL68=1: LVDS input data is 8bits (VESA)

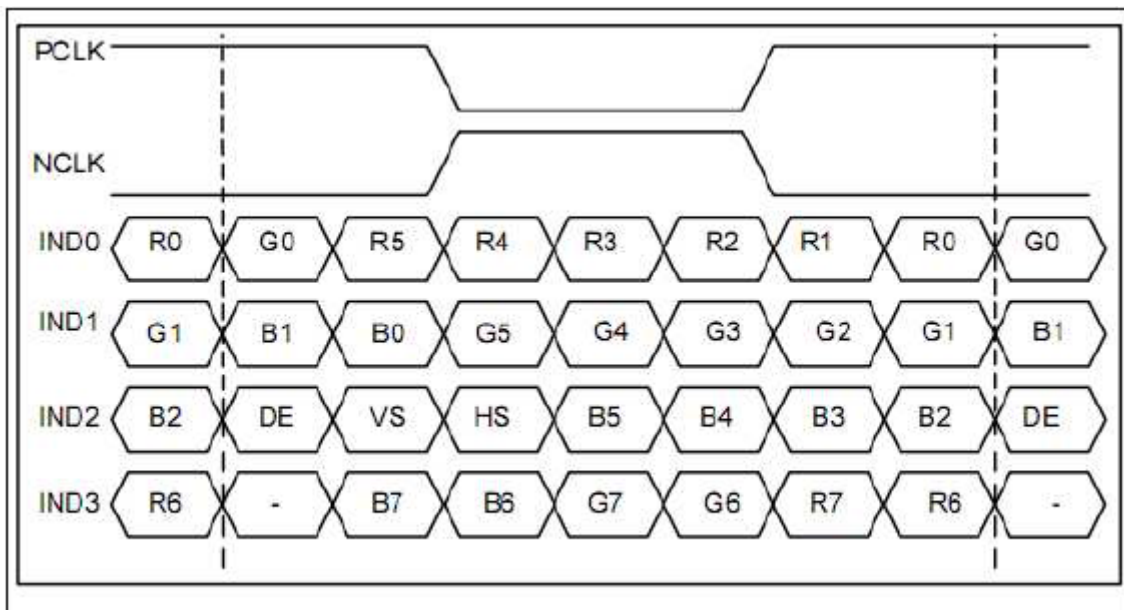

#### 4.4 Interface Timing (DE mode)

Item	Symbol	Min.	Typ.	Max.	Unit
Frame Rate	--	55	60	65	Hz
Vertical Total Time	TV	783	798	813	line
Vertical Display Time	TVD	768			line
Vertical Blanking Time	TVB	15	30	45	line
Horizontal Total Time	TH	1104	1124	1144	clock
Horizontal Display Time	THD	1024			clock
Horizontal Blanking Time	THB	80	100	120	clock
Clock Rate	1/ TClock	51.2	53.8	56.2	MHz

#### Timing Diagram of Interface Signal (DE mode)

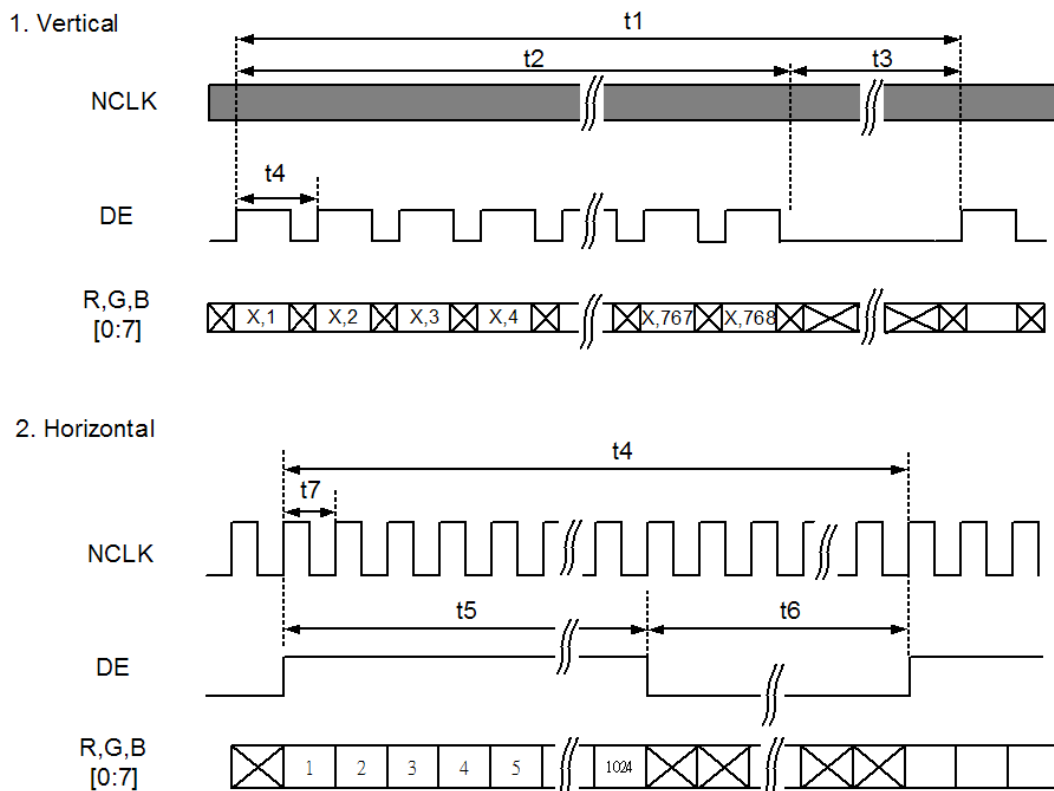

## 5. Backlight Unit

### 5.1 White LED Backlight

(It's for design reference only, The Backlight driving by built-in LED Driver)

Item	Symbol	Min.	Typ.	Max.	Unit	Condition
Input Voltage	VL	--	12.0	--	V	
Input Current	I <sub>LED</sub>	--	1.3	--	A	100% PWM duty
BLEN Logic High	V <sub>IH</sub>	2.5	--	VL	V	
BLEN Logic Low	V <sub>IL</sub>	0	--	0.4	V	
V <sub>PDIM</sub> Logic High	V <sub>IH</sub>	2.5	--	5.5	V	
V <sub>PDIM</sub> Logic Low	V <sub>IL</sub>	0	--	0.4	V	
V <sub>PDIM</sub> PWM Frequency	F <sub>PDIM</sub>	100	500	1000	Hz	
V <sub>PDIM</sub> PWM Duty Range	DR	5	--	100	%	
LED Backlight Voltage	V <sub>F</sub>	--	27	--	V	For reference
LED Backlight Current	I <sub>F</sub>	-	420	--	mA	Ta=25°C
LED Life Time		--	30	-	Khr	

Note(1) Ta means ambient temperature of TFT-LCD module.

Note(2) V<sub>F</sub>, I<sub>F</sub> are defined for LED B/L.

Note(3) If the module is driven by high current or at high ambient temperature & humidity condition. The operating life will be reduced.

Note(4) Operating life means brightness goes down to 50% minimum brightness. LED life time is estimated data. Ta=25°C

Note(5) The structure of LED B/L shows as below.



Note(6) When LCM is operated over 40°C ambient temperature, the I<sub>F</sub> should be follow :

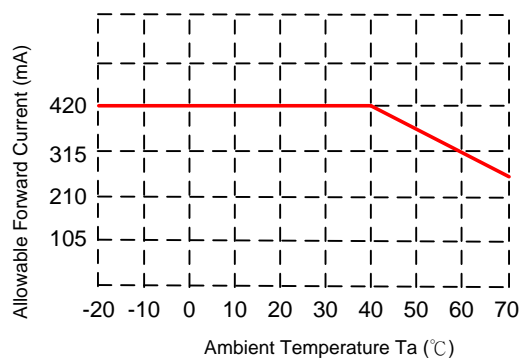



## 6. Interface

### 6.1 Interface Connector (Input signal):

STARCONN 076B20-0048RA-G4 or JAE FI-SEB20P-HFE (or equivalent)

Pin NO.	Symbol	Description	Note
1	RX3+	Differential Data Input, CH3 ( Positive )	
2	RX3-	Differential Data Input, CH3 (Negative )	
3	BIST	Normal operation/BIST pattern select BIST="0": Normal operation BIST="1" : BIST mode	Note(1)
4	SEL68	6bit/8bit mode select SELB = "1" : LVDS input data is 8bits SELB = "0" : LVDS input data is 6bits	Note(1)
5	GND	Ground	
6	RXC+	Differential Clock Input ( Positive )	
7	RXC-	Differential Clock Input ( Negative )	
8	GND	Ground	
9	RX2+	Differential Data Input , CH2 ( Positive )	
10	RX2-	Differential Data Input , CH2 ( Negative )	
11	GND	Ground	
12	RX1+	Differential Data Input , CH1 ( Positive )	
13	RX1-	Differential Data Input, CH1 ( Negative )	
14	GND	Ground	
15	RX0+	Differential Data Input, CH0 ( Positive )	
16	RX0-	Differential Data Input, CH0 (Negative )	
17	reLR	Left or Right display control SHLR = "1" : Left SHLR = "0" : Right	Note(2)
18	reUD	Up/Down display control UPDN = "1" : Up UPDN = "0" : Down	Note(2)
19	VDD	Power supply, 3.3V	
20	VDD	Power supply, 3.3V	

Note(1) The high level voltage "1" is 3.3V, and the low level voltage "0" is GND.

Note(2) UPDN and SHLR control function

reLR	reUD	Data shifting
1	0	Left , Down
0	0	Right , Down
1	1	Left , Up
0	1	Right , Up

## 6.2 Backlight Pin Assignment

Connector: FI-S8P-HEF JAE (or equivalent)

Mating Connector: FI-S8S (JAE)

Pin NO.	Symbol	Description	Note
1	VL	LED Driver input voltage	12V
2	VL	LED Driver input voltage	12V
3	VL	LED Driver input voltage	12V
4	GNDL	LED Driver ground	Ground
5	GNDL	LED Driver ground	Ground
6	GNDL	LED Driver ground	Ground
7	BLEN	LED Driver Enable pin. High : LED Back-light ON Low : LED Back-light Low	12V
8	VPDIM	PWM input for backlight brightness adjust	

## 7. Optical Specifications

Item		Symbol	Condition	Min.	Typ.	Max.	Unit	Note
Contrast		CR	Θ=0 Normal viewing angle	700	1000	—		(1)(2)
Response time	Rising	TR+TF		—	25	35	msec	(1)(3)
	Falling							
White luminance (Center)		YL		<b>1000</b>	<b>1300</b>	—	cd/m <sup>2</sup>	(1)(4)
Color chromaticity (CIE1931)	White	Wx		Typ. -0.05	Typ. +0.05	0.34		(1)(4)
		Wy				0.39		
	Red	Rx				0.68		
		Ry				0.31		
	Green	Gx				0.29		
		Gy				0.67		
	Blue	Bx	0.10					
		By	0.14					
Viewing angle	Hor.	ΘL	80	85	—			
		ΘR	80	85	—			
	Ver.	ΘU	80	85	—			
		ΘD	80	85	—			
Brightness uniformity		BUNI	Θ=0	70	80	—	%	(5)
NTSC			--	--	<b>85</b>	--	%	
Optima View Direction		Free						(6)

Note(1) Definition of Viewing Angle :

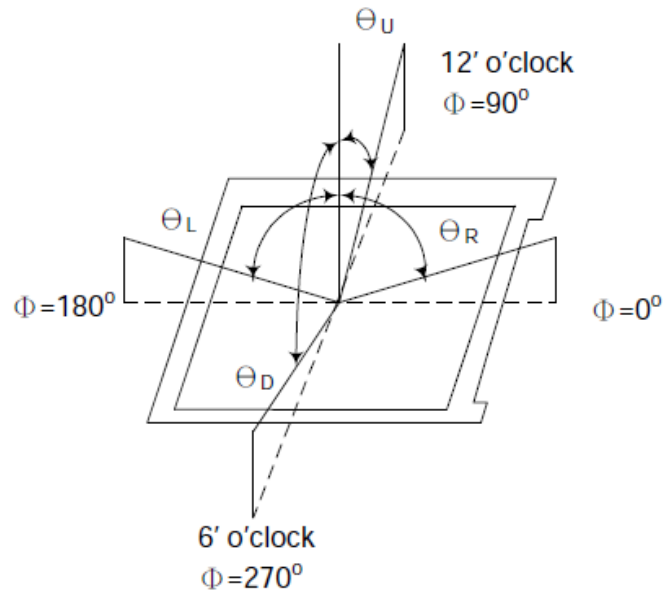

Note(2) Definition of Contrast Ratio (CR) : Measured at the center point of panel

$$CR = \frac{\text{Luminance with all pixels white}}{\text{Luminance with all pixels black}}$$

Note(3) Definition of Response Time : Sum of TR and TF

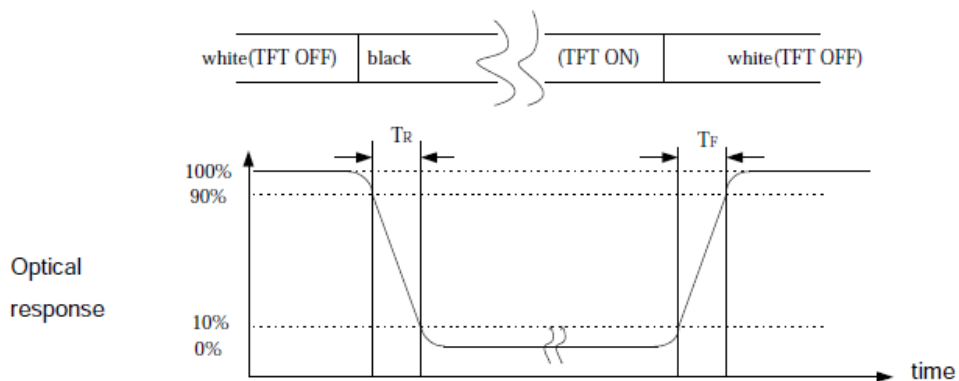

Note(4) Definition of optical measurement setup

The optical characteristics should be measured in dark room. After 30 minutes operation, the optical properties are measured at the center point of the LCD screen. (Response time is measured by Photo detector TOPCON BM-7, other items are measured by BM-5A/Field of view: 1° / Height: 500mm.)

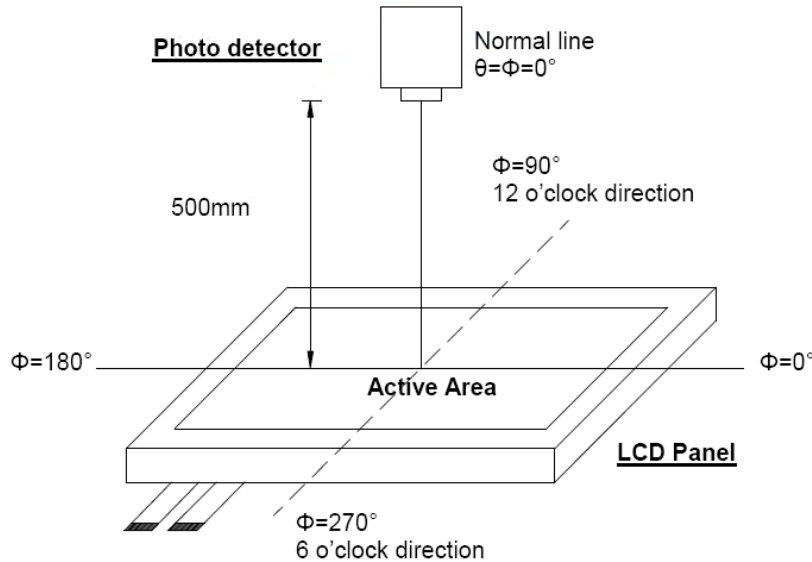

Note(5) Definition of brightness uniformity

Active area is divided into 9 measuring areas (Refer to bellow figure). Every measuring point is placed at the center of each measuring area.

$$\text{Luminance Uniformity (Yu)} = \frac{B_{\min}}{B_{\max}}$$

L ----- Active area length      W ----- Active area width

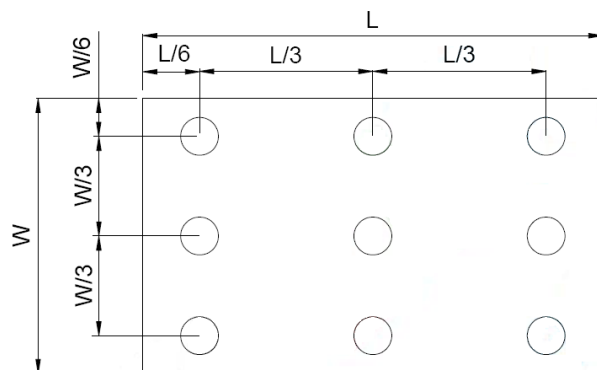

B<sub>max</sub>: The measured maximum luminance of all measurement position.  
 B<sub>min</sub>: The measured minimum luminance of all measurement position.

Note(6) Rubbing Direction (The different Rubbing Direction will cause the different optima view direction.)

## 8. Power On / Off Sequence

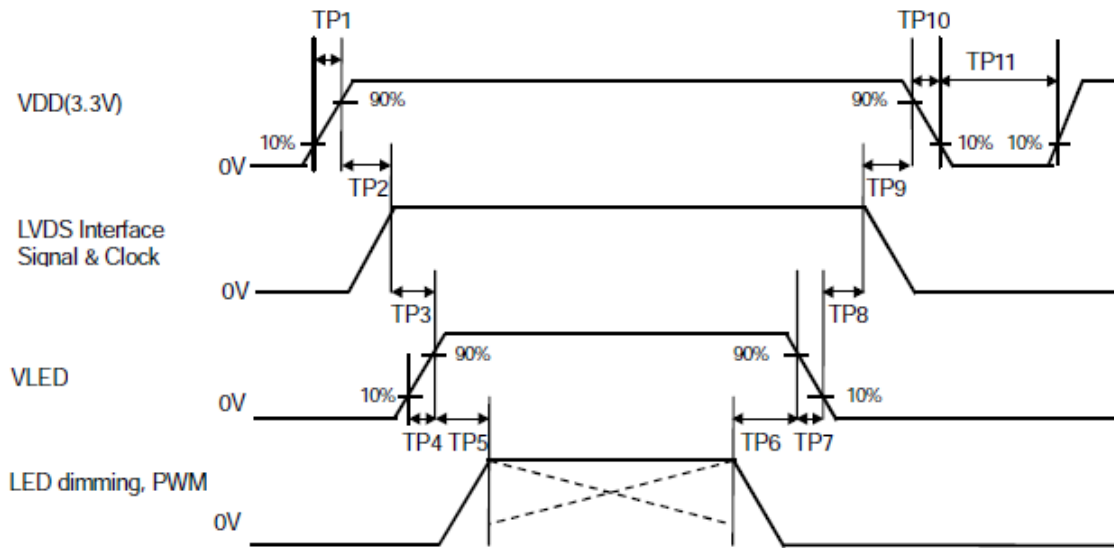

Item	Min.	Typ.	Max.	Unit
TP1	0.5	--	10	msec
TP2	0	--	50	msec
TP3	200	--	--	msec
TP4	0.5	--	10	msec
TP5	10	--	--	msec
TP6	10	--	--	msec
TP7	0	--	10	msec
TP8	200	--	--	msec
TP9	0	--	50	msec
TP10	0	--	10	msec
TP11	1000	--	--	msec

## 9. Reliability Test Conditions

Test Item	Test Conditions	Note
High Temperature Operation	70±3°C ,Dry t=240 hrs	
Low Temperature Operation	-30±3°C, Dry t=240 hrs	
High Temperature Storage	80±3°C , Dry t=240 hrs	1,2
Low Temperature Storage	-30±3°C ,Dry t=240 hrs	1,2
Thermal Shock Test	-30°C ~ 25°C ~ 70°C 30 min. 5 min. 30 min. ( 1 cycle ) Total 100 cycle(Dry)	1,2
Storage Humidity Test	60 °C, Humidity 90%, 240 hrs	1,2
Vibration Test (Packing)	Sweep frequency : 10 ~ 55 ~ 10 Hz/1min Amplitude : 0.75mm Test direction : X.Y.Z/3 axis Duration : 30min/each axis	2

Note(1) Condensation of water is not permitted on the module.

Note(2) The module should be inspected after 1 hour storage in normal conditions.  
(15-35°C, 45-65%RH)

Note(3) The module shouldn't be tested over one condition, and all the tests are independent.

Note(4) All reliability tests should be done without the protective film.

Definitions of life end point:

- Current drain should be smaller than the specific value.
- Function of the module should be maintained.
- Appearance and display quality should not have degraded noticeably.
- Contrast ratio should be greater than 50% of the initial value.

## **10. General Precaution**

### **8.1 Use Restriction**

- (1) This product is not authorized for use in life supporting systems, aircraft navigation control systems, military systems and any other application where performance failure could be life-threatening or otherwise catastrophic.

### **8.2 Disassembling or Modification**

- (1) Do not disassemble or modify the module. It may damage sensitive parts inside LCD module, and may cause scratches or dust on the display. AMPIRE does not warrant the module, if customers disassemble or modify the module.

### **8.3 Breakage of LCD Panel**

- (1) If LCD panel is broken and liquid crystal spills out, do not ingest or inhale liquid crystal, and do not contact liquid crystal with skin.
- (2) If liquid crystal contacts mouth or eyes, rinse out with water immediately.
- (3) If liquid crystal contacts skin or cloths, wash it off immediately with alcohol and rinse thoroughly with water.
- (4) Handle carefully with chips of glass that may cause injury, when the glass is broken.

### **8.4 Electric Shock**

- (1) Disconnect power supply before handling LCD module.
- (2) Do not pull or fold the LED cable.
- (3) Do not touch the parts inside LCD modules and the fluorescent LED's connector or cables in order to prevent electric shock.

### **8.5 Absolute Maximum Ratings and Power Protection Circuit**

- (1) Do not exceed the absolute maximum rating values, such as the supply voltage variation, input voltage variation, variation in parts' parameters, environmental temperature, etc., otherwise LCD module may be damaged.
- (2) Please do not leave LCD module in the environment of high humidity and high temperature for a long time.
- (3) It's recommended to employ protection circuit for power supply.



## 8.6 Operation

- (1) Do not touch, push or rub the polarizer with anything harder than HB pencil lead.
- (2) Use fingerstalls of soft gloves in order to keep clean display quality, when persons handle the LCD module for incoming inspection or assembly.
- (3) When the surface is dusty, please wipe gently with absorbent cotton or other soft material.
- (4) Wipe off saliva or water drops as soon as possible. If saliva or water drops contact with polarizer for a long time, they may cause deformation or color fading.
- (5) When cleaning the adhesives, please use absorbent cotton wetted with a little petroleum benzene or other adequate solvent.

## 8.7 Static Electricity

- (1) Protection film must remove very slowly from the surface of LCD module to prevent from electrostatic occurrence.
- (2) Because LCD modules use CMOS-IC on circuit board and TFT-LCD panel, it is very weak to electrostatic discharge. Please be careful with electrostatic discharge. Persons who handle the module should be grounded through adequate methods.

## 8.8 Strong Light Exposure

- (1) The module shall not be exposed under strong light such as direct sunlight. Otherwise, display characteristics may be changed.

## 8.9 Disposal

- (1) When disposing LCD module, obey the local environmental regulations.

## 8.10 Others

- (1) AMIPRE will provide one year warrantee for all products and three months warrantee for all repairing products.
- (2) Do not keep the LCD at the same display pattern continually. The residual image will happen and it will damage the LCD. Please use screen saver.

# 11. Outline Dimension

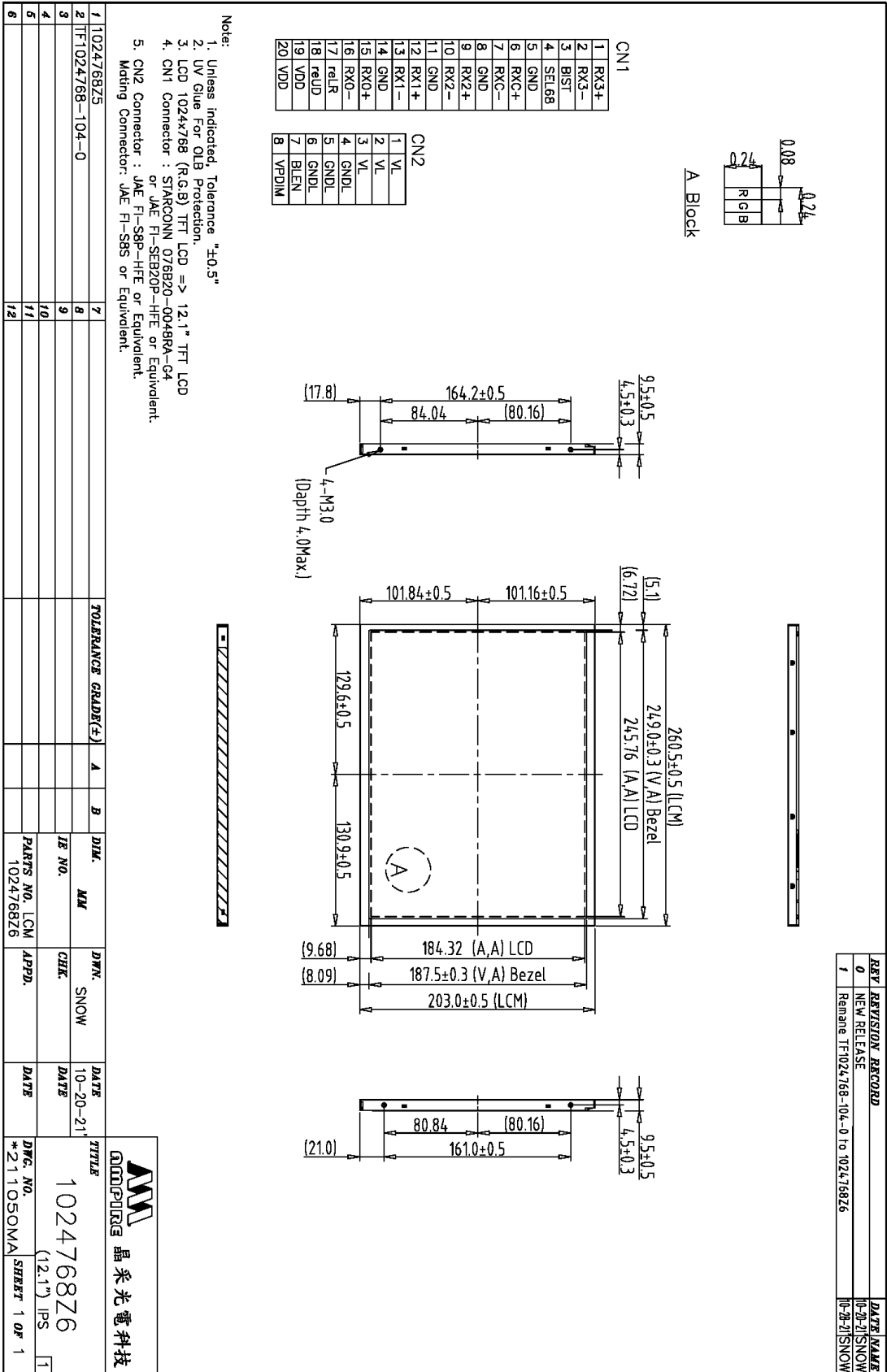

REV.	REVISION RECORD	DATE	NAME
0	NEW RELEASE	10-20-21	SNOW
1	Rename TF1024768-104-0 to 1024768Z6	10-20-21	SNOW

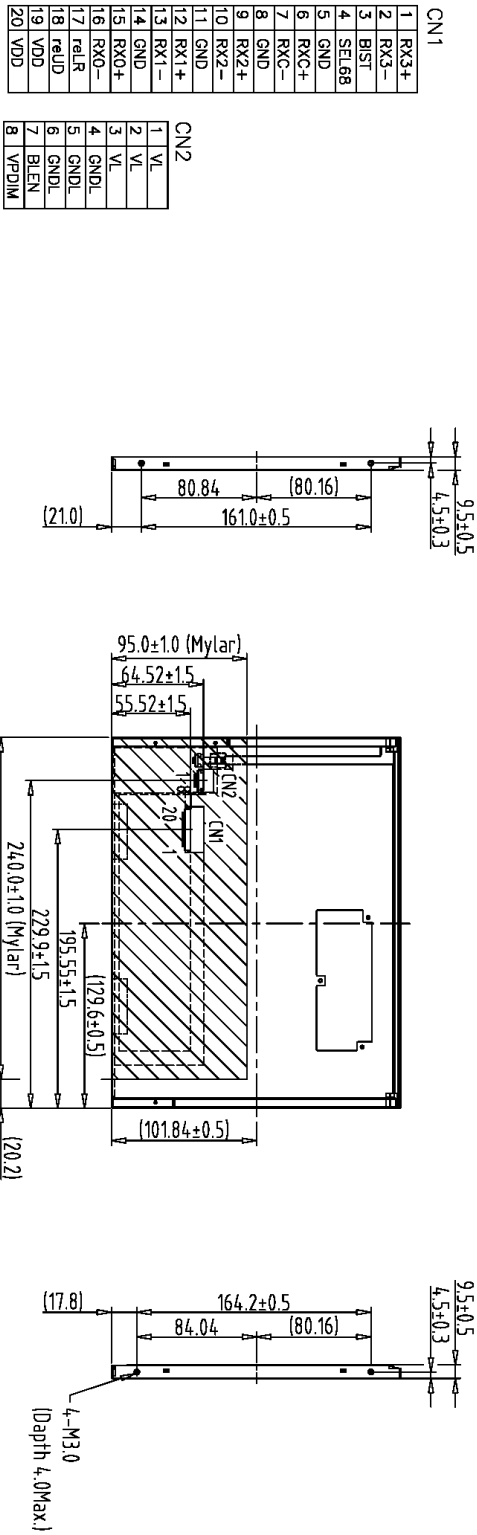

CN1

1	RX3+
2	RX3-
3	BIST
4	SEL68
5	GND
6	RXC+
7	RXC-
8	GND
9	RX2+
10	RX2-
11	GND
12	RX1+
13	RX1-
14	GND
15	RX0+
16	RX0-
17	reLR
18	reLUD
19	VDD
20	VDD

CN2

1	VL
2	VL
3	VL
4	GNDL
5	GNDL
6	GNDL
7	BLEN
8	VPDIM

- Note:
1. Unless indicated, Tolerance "±0.5"
  2. UV Glue For OLB Protection.
  3. LCD 1024x768 (R.G.B) TFT LCD => 12.1" TFT LCD
  4. CN1 Connector : STARCONN 076820-0046RA-G4 or JAE FI-SE820P-HFE or Equivalent.
  5. CN2 Connector : JAE FI-S8P-HFE or Equivalent. Mating Connector: JAE FI-S8S or Equivalent.

Back view

REV.	DATE	NAME	APPD.	CHEK.	DATE	DATE	DATE	DATE	DATE
1	1024768Z6								
2	TF1024768-104-0								
3									
4									
5									
6									

TITLE	DWG. NO.	SHEET	1 OF 1
AMU 晶采光电科技	1024768Z6	(12.1")	IPS
QUINPRO	*211051MA		

# 12. Package

Note:  
 1. Bag = 1 PCS LCM  
 2. Big Box = 1x 10 = 10 PCS LCM

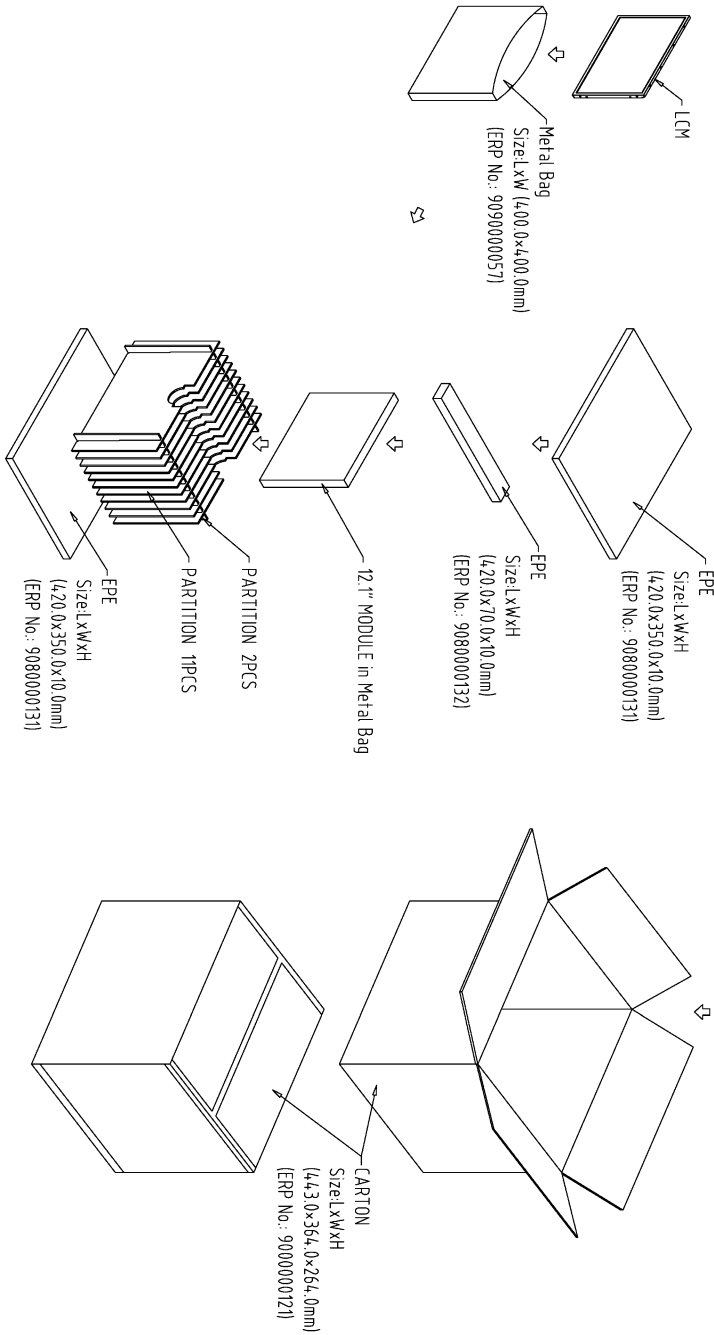

REV.	REVISION RECORD	DATE	NAME
0	NEW RELEASE	04-28-22	SNOW

NO.	DESCRIPTION	DATE	NAME
1			
2			
3			
4			
5			
6			
7	TOLERANCE GRADE(%)	A	B
8			
9			
10			
11			
12			

晶采光電科技  
**1024768Z5**  
 (12.1") IPS  
 DWG. NO. \*220417SSA  
 SHEET 1 OF 1